

# INSTALLATION INSTRUCTIONS

## Contempo Tub Spout

Part #: 8230

# JACLO®

Confidence from start to finish.™



# PARTS

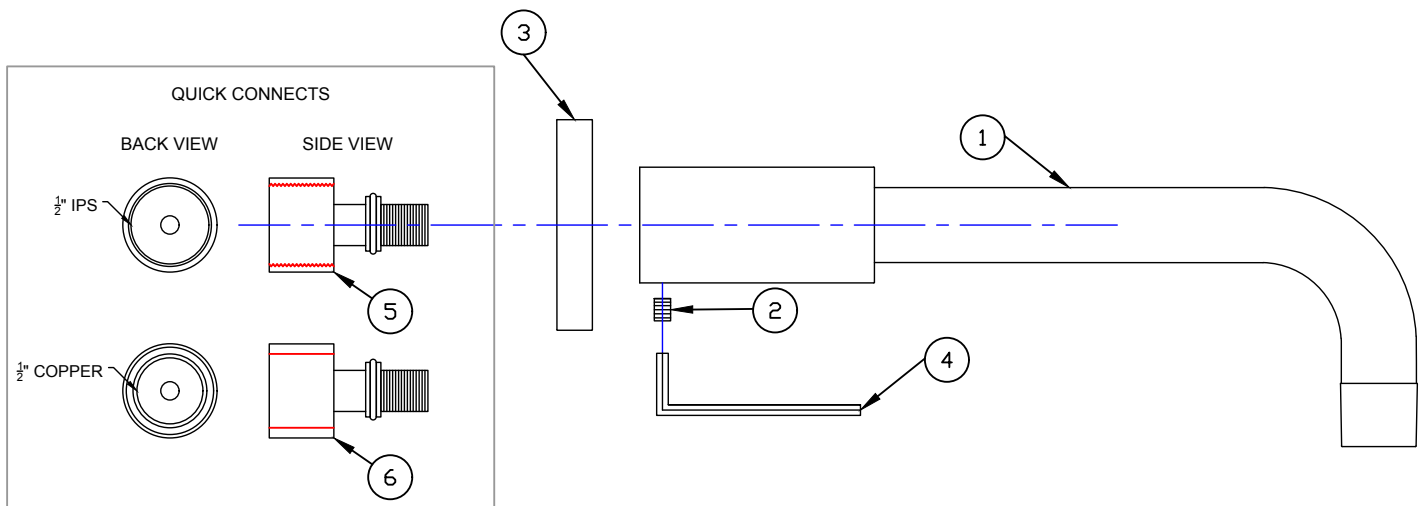

COMPONENT PARTS	
1	SPOUT
2	SET SCREW
3	ESCUTCHEON
4	ALLEN KEY
5	1/2" IPS QUICK CONNECT
6	1/2" COPPER QUICK CONNECT

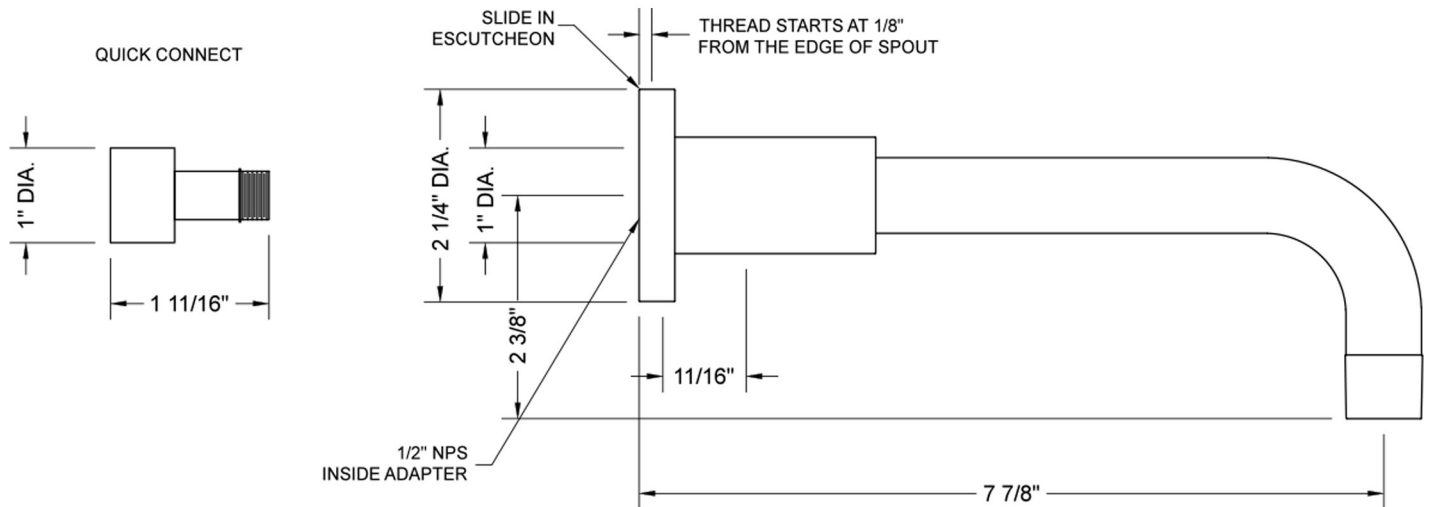

## TUB SPOUT INSTALLATION

1. Determine installation 1/2" IPS or 1/2" copper sweat.

\*Pipe should protrude through finished wall 3/4"\*

\*\*NOTE: ADAPTERS SUPPLIED TO RECEIVE 1/2" IPS MALE NIPPLE OR 1/2" COPPER TUBING\*\*

2. Loosen set screw located in back of spout and put in secure location.
3. Remove quick connect FROM SPOUT using 1/4" allen key.
4. Affix quick connect to IPS or copper using appropriate procedures.
5. Lubricate o-ring of quick connect.
6. Screw tub spout onto quick connect.
7. Tighten set screw.
8. Slide escutcheon over spout.

# Over Fifty Years of Excellence Proud to be an American Company



## CARE INSTRUCTIONS

In order to maintain the high quality finish of JACLO products, please adhere to the following product care instructions:

**Cleaning JACLO products:** For routine cleaning, simply use a soft damp cloth and common household soap, then rinse and dry. Proper care of your product is important because most water contains calcium that deposits on surfaces, forming unpleasant spots. This can be avoided by routine cleaning and drying after every use. Use only mild soap detergents. JACLO products may be periodically waxed with non abrasive compounds, such as Flitz® faucet wax.

Never use abrasive cleaners, bleach, disinfectants or cleaning products containing alcohol, ammonia, hydrochloric or phosphoric acids as they will damage the product finish.

**Please note:** Your product warranty may not be valid if the above cleaning guidelines are not followed.

## WARRANTY

**Residential Warranty:** Your new plumbing fixture is warranted by JACLO INDUSTRIES, 129 Dermody Street, Cranford, NJ 07016. This warranty is extended to original consumer purchasers only. This warranty gives you specific legal rights, and you may also have other rights which vary from state to state.

The product (including the finish on the product but excluding any custom finishes and any installation hardware not supplied by JACLO) is warranted to be free from defects in material or workmanship under normal use and service for the lifetime\* of the fixture, so long as the original consumer purchaser owns it. JACLO's sole obligation under this or any other warranty is limited to repairing or replacing at JACLO's option, without labor, any part or parts of the fixture which fail to conform to such warranty.

**JACLO WILL NOT BE LIABLE FOR ANY CONSEQUENTIAL OR INCIDENTAL DAMAGES CAUSED BY A BREACH OF THIS OR ANY OTHER WARRANTY.**

Some states do not allow the exclusion of limitation of incidental or consequential damages, so the above limitation may not apply to you.

To secure warranty performance, the original consumer purchaser must have the fixture properly and professionally installed in accordance with all codes and installation instructions.

Items and actions that will void the JACLO warranty are:

- Abuse, misuse, neglect and accidental damage
- Improper cleaning, care and maintenance of the fixture
- Alteration of the fixture in any way including removal of a flow regulator/restrictor

All warranty claims must be made in accordance with the JACLO return policy (see below).

JACLO does not authorize any distributor, retailer or other person to modify this warranty or assume any liability on its behalf with respect to it. Any question regarding the operation of warranty should be addressed to JACLO's warranty department.

\*Due to the unpredictable environment, all kitchen drains, strainers and garbage disposal flanges are warranted for the period of one year from date of purchase from an authorized JACLO dealer.

Un-lacquered Brass (ULB) is a living finish and is excluded from any finish warranty.

**Commercial Warranty:** JACLO offers the above warranty for a period of one year from date of purchase to purchasers of products for industrial, commercial, business and all non-private residential uses.

